

Mathematics Mastery

5-week maths pack

Guidance on using these resources:

We have mapped out five weeks of activities consisting of four sessions in each week.

Each session is designed to last 1 hour and consists of:

- Two tasks contained within this pack (20 minutes)
- A practice exercise linked to the tasks contained in the exercise pack (40 minutes)

The focus for each of the weeks and the session titles are shown in the timetable below:

	Session title	Learning outcome
Week 1: Transformations	Translation	Translate a shape by a given vector
	Rotation	Rotate a shape around a point of rotation
	Reflection	Reflect a shape in a line of reflection
	Isometries	Recognise transformations that conserve shape dimensions
Week 2: More transformations	Combining reflections	Find the resulting transformation when reflections are combined
	Combining translations and reflections	Look at the effect for combining translations and reflections in different orders
	Enlargements	Enlarge a shape by a given scale factor
	Enlargement and area	Look at how area is affected by an enlargement
Week 3: Prime factorisation 1	Indices	Use indice notation
	Prime factors	Find the prime factors of a number
	Prime factorisation	Write a number as a product of prime factors
	Using the prime factorisation	Use the prime factorisation to recognise properties of numbers
Week 4: Prime factorisation 2	Highest common factor	Find the highest common factor of two numbers
	More highest common factor	Compare strategies for finding the highest common factor
	Lowest common multiple	Find the lowest common multiple of two numbers
	More lowest common multiple	Compare strategies for finding the lowest common multiple
Week 5: Fractions	Part of a whole	Understand fractions as part of a whole
	Fractions of measure	Understand fractions as a measure
	Fair shares	Understand fractions as the result of dividing up an amount
	Equivalence	Understand and recognise equivalent fractions

How can I check my answers are correct?

We will be releasing full answers to this booklet and the practice exercises within the next week

What can I use at the end of this five-week pack?

Further resources will be released for students to use at home over the coming weeks. Sign up to receive regular updates at mathematicsmastery.org

Can parents, carers and siblings help?

Yes of course! They can help you by working through the tasks together and being someone to talk about the maths with. They can also help you check your work once you are finished each session.

Task 1

Translations are movements in a direction.

Column vectors can be used to describe translations.

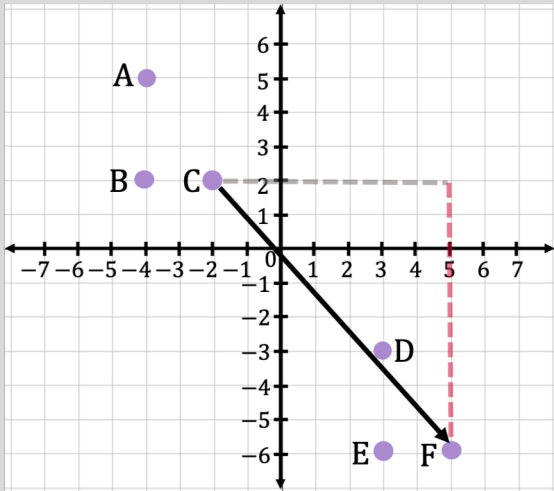

7 units in the positive x -direction

C to F : $\begin{pmatrix} 7 \\ -8 \end{pmatrix}$

8 units in the negative y -direction

Write a vector that can describe the translations :

F to C

D to B

B to C

A to B

Task 2

Describe the translations from the central rectangle to the surrounding rectangles in each case.

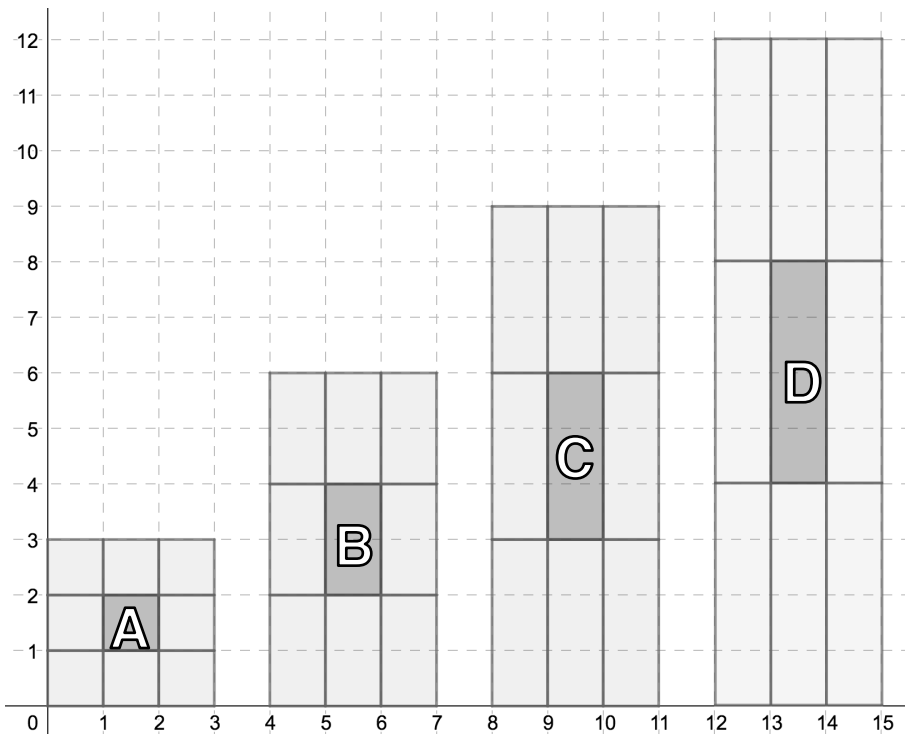

How could you continue this pattern?

Task 1

We can rotate shapes about a **point of rotation**.

Angle of rotation : 90° clockwise

- Tracing paper
- Image
- Circles
- Point of rotation
- Angle of rotation



Access the Geogebra file on this link:
<https://www.geogebra.org/classic/vneqtrf>

Task 2

Copy this image, rotate the hexagon 90° clockwise about the black crosses and 90° anticlockwise about the black dots.

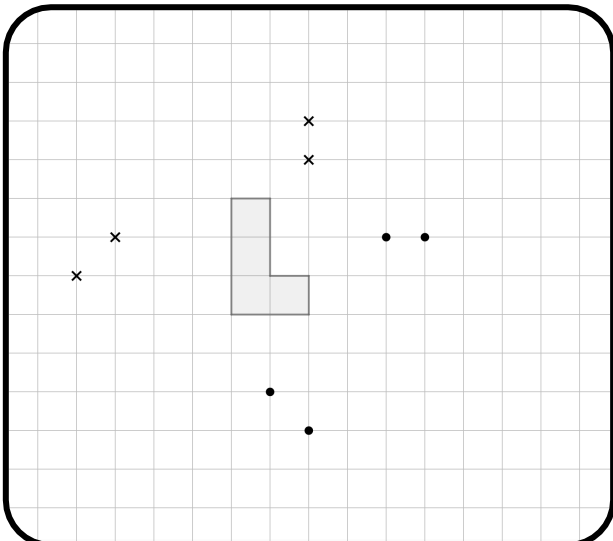

How would moving the points of rotation will affect the image?

Task 1

We can reflect shapes in a line of reflection.

Points and their reflections will be equidistance from this line.

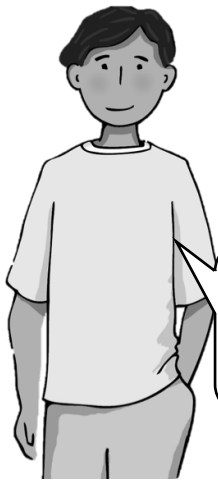
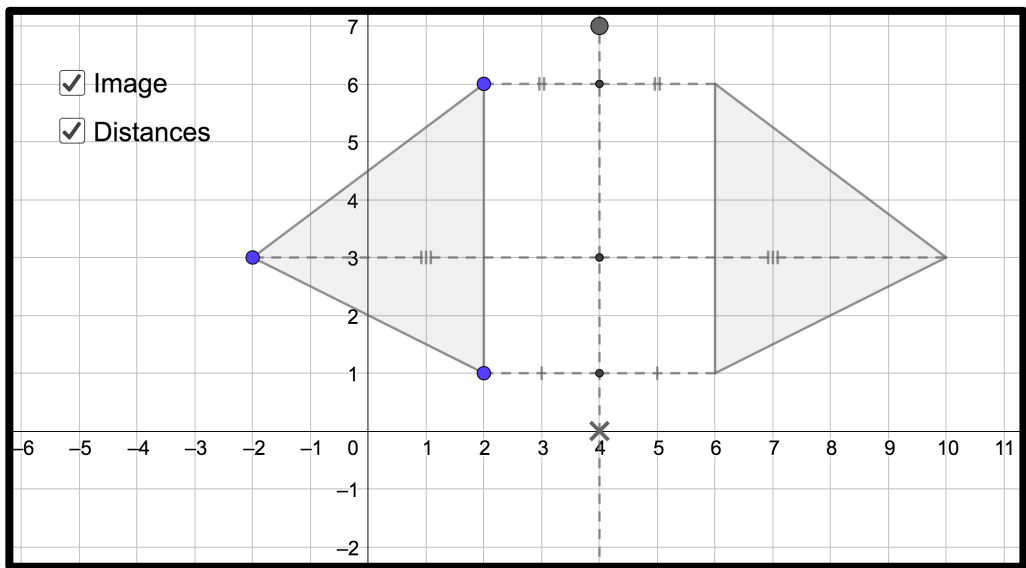

Access the Geogebra file on this link:
https://www.geogebra.org/classic/c5fmv_hfw

Task 2

T and U are reflections of S. What are the lines of reflection?

Explore the effect on the **reflected images** if **S** is translated by the vectors:

- $\begin{pmatrix} 1 \\ 0 \end{pmatrix}$
- $\begin{pmatrix} 0 \\ 1 \end{pmatrix}$
- $\begin{pmatrix} 1 \\ -1 \end{pmatrix}$

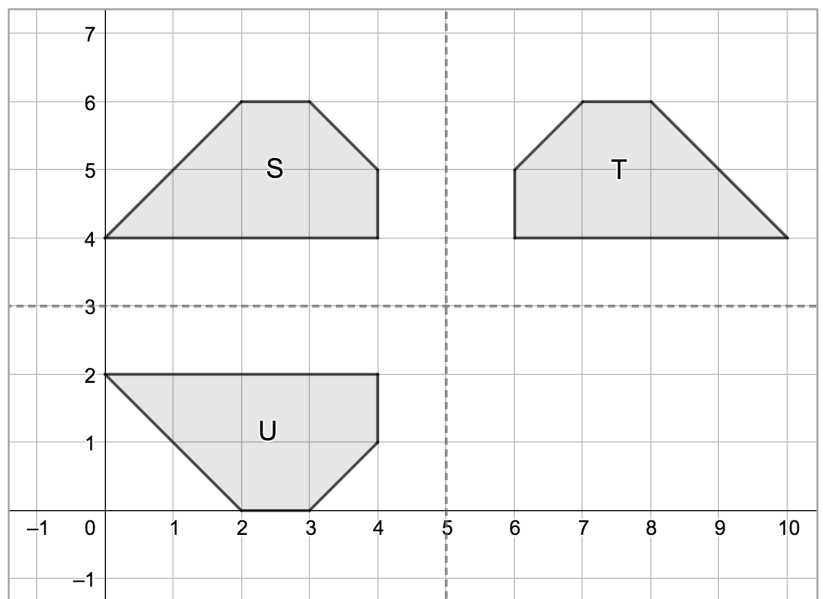

Task 1

Copy and add in more examples and non examples

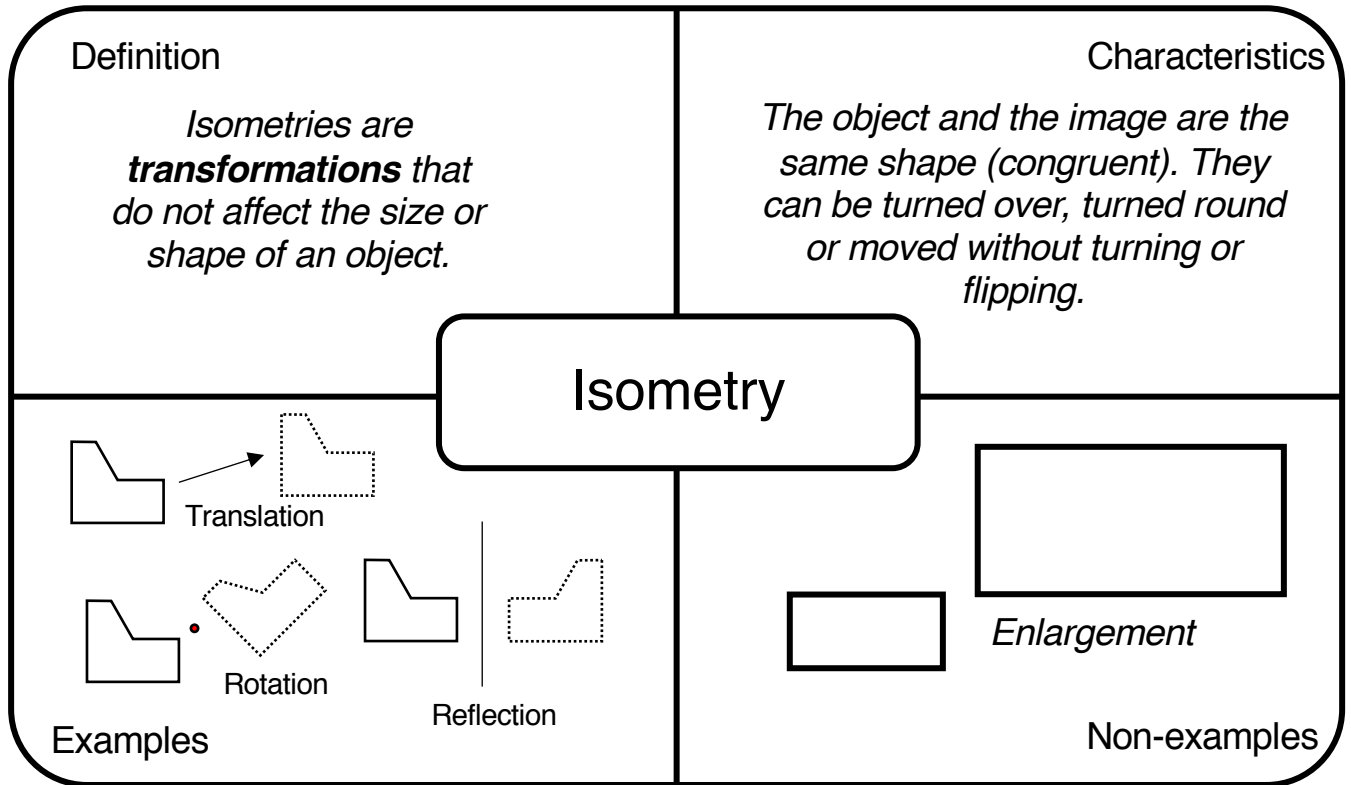

Task 2

There are different ways to transform one of the squares onto the other. Complete the descriptions:

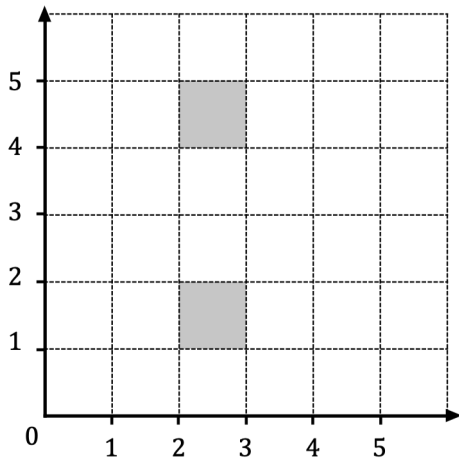

I reflected ...

I rotated ...

I translated ...

Task 1

We can sometimes describe the effect of **combining** transformations using a single transformation.

Reflecting S in M_1 then in M_2 has the same effect as a translation

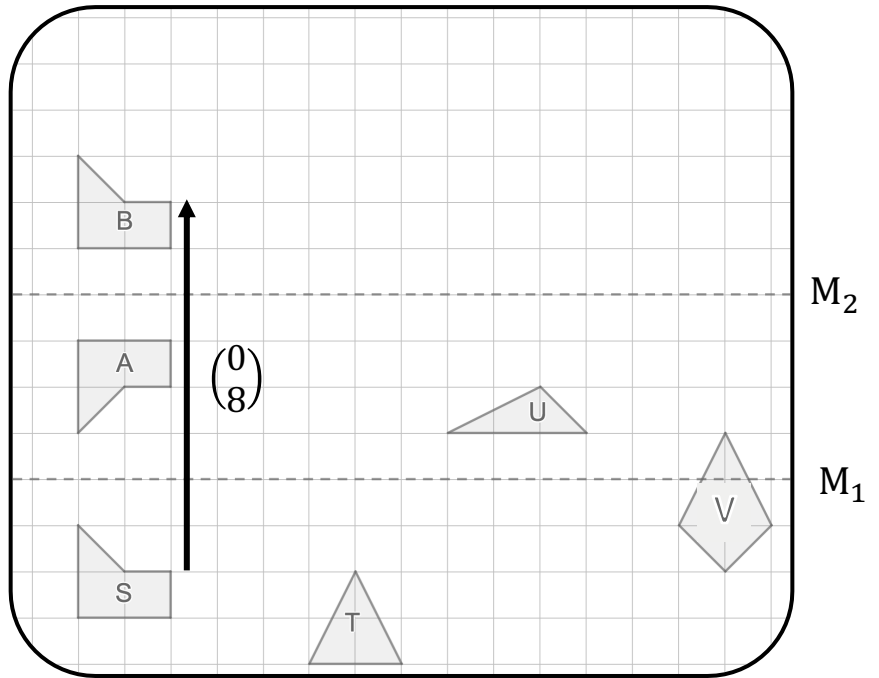

Explore the effect of this combination of reflections for: T, U and V.

Task 2

Reflect S in M_1 then in M_2 . Describe the single transformation from S to the final image.

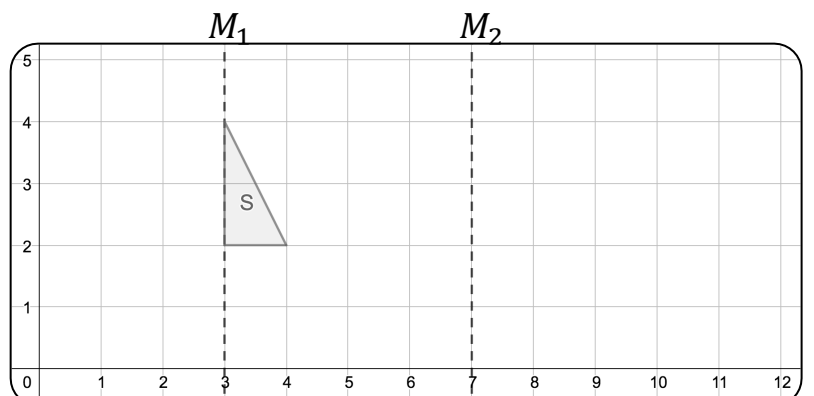
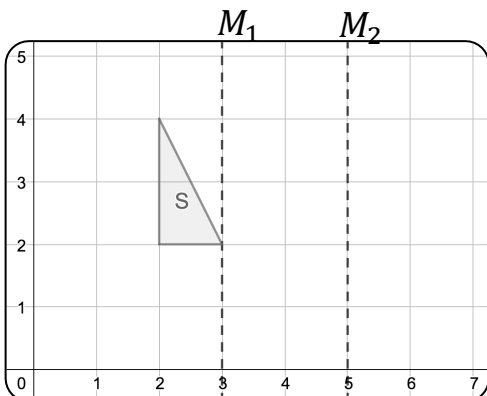
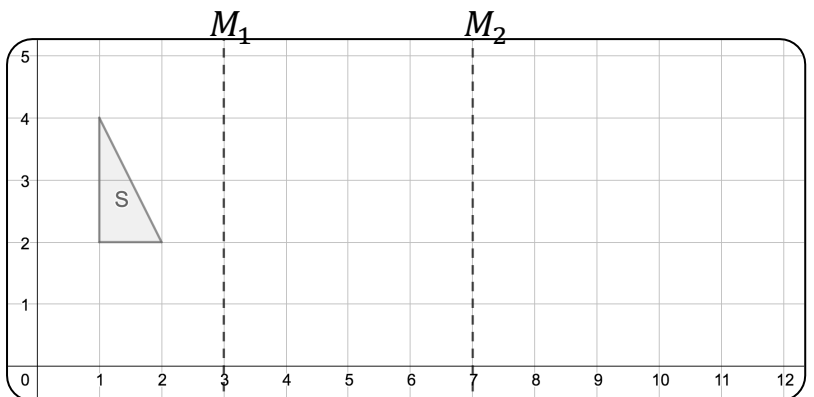
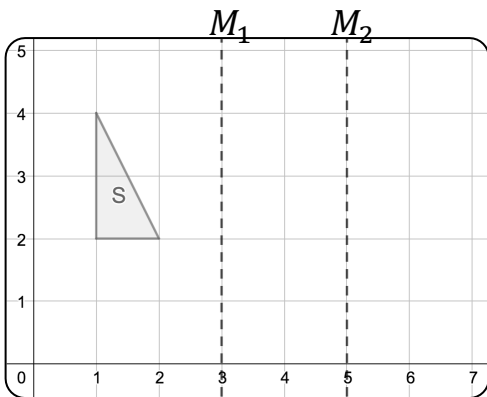

Task 1

Describe the transformation, or combination of transformations, between each pair of triangles:

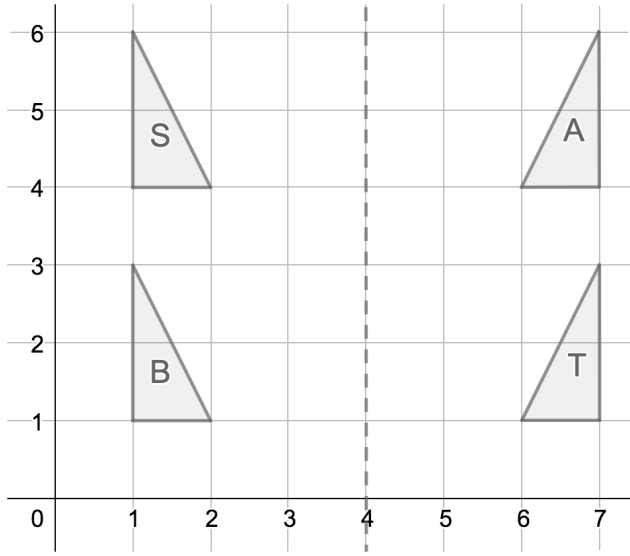

e.g. Triangle T is the reflection of triangle S in the line $x = 4$ followed by a translation by the vector $\begin{pmatrix} 0 \\ -3 \end{pmatrix}$

Task 2

Using the line of symmetry shown, compare the effect of...

- reflecting then translating
- translating then reflecting

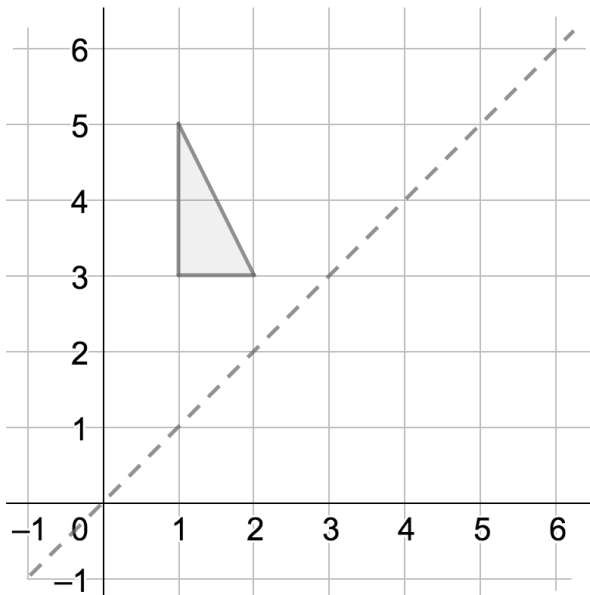

... for each of the vectors:

Five vectors are shown in rounded rectangular boxes:

- $\begin{pmatrix} 1 \\ 0 \end{pmatrix}$
- $\begin{pmatrix} 0 \\ -3 \end{pmatrix}$
- $\begin{pmatrix} 1 \\ 2 \end{pmatrix}$
- $\begin{pmatrix} -2 \\ -2 \end{pmatrix}$
- $\begin{pmatrix} 1 \\ 1 \end{pmatrix}$

Task 1

Enlargements of shapes can be described using **scale factors**.

T is an enlargement of S by a scale factor 2

S is an enlargement of T by a scale factor $\frac{1}{2}$

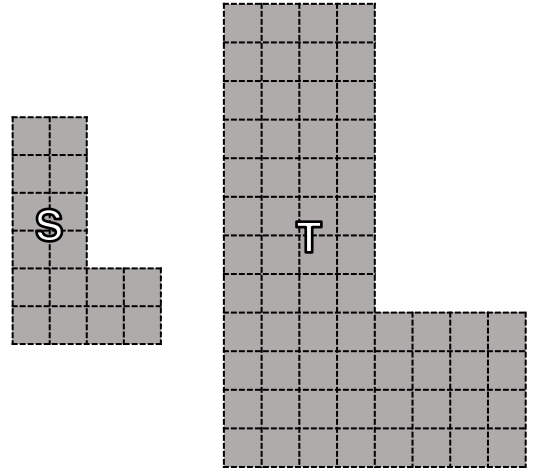

Draw S following an enlargement of scale factor:

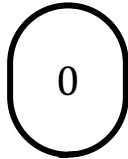
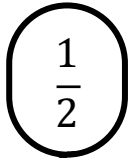
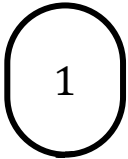
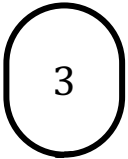

Task 2

Explain why B is not an enlargement of A.

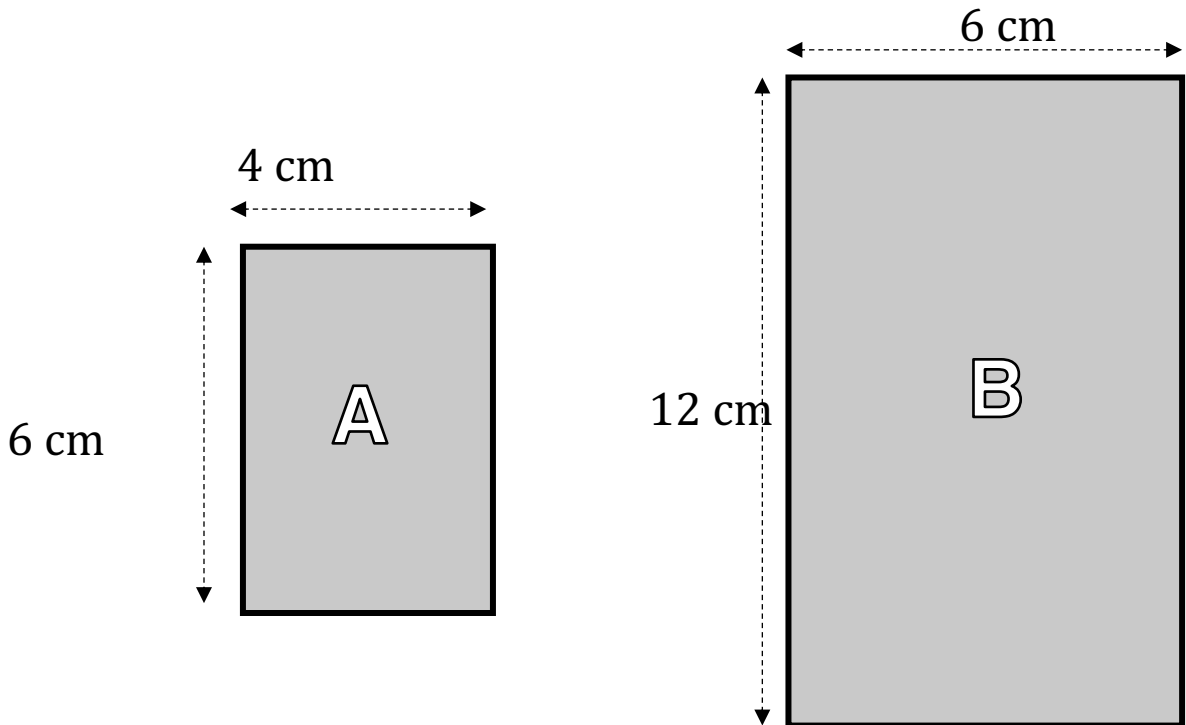

How could you change **one of the dimensions** of A or B so that it is?

Task 1

When a shape is enlarged the **area** is affected.

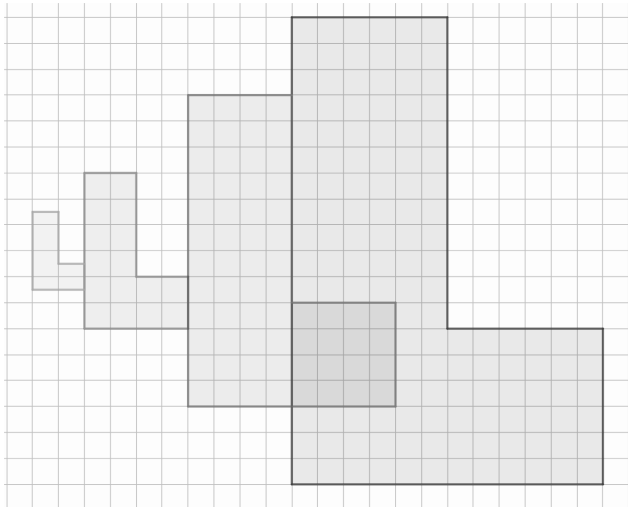

Find the scale factor of enlargement between the different shapes.

How has the area been affected in each case?

Task 2

Draw **sketches** of the following shapes after they're enlarged by a scale factor 7.

How do enlargements affect the areas?

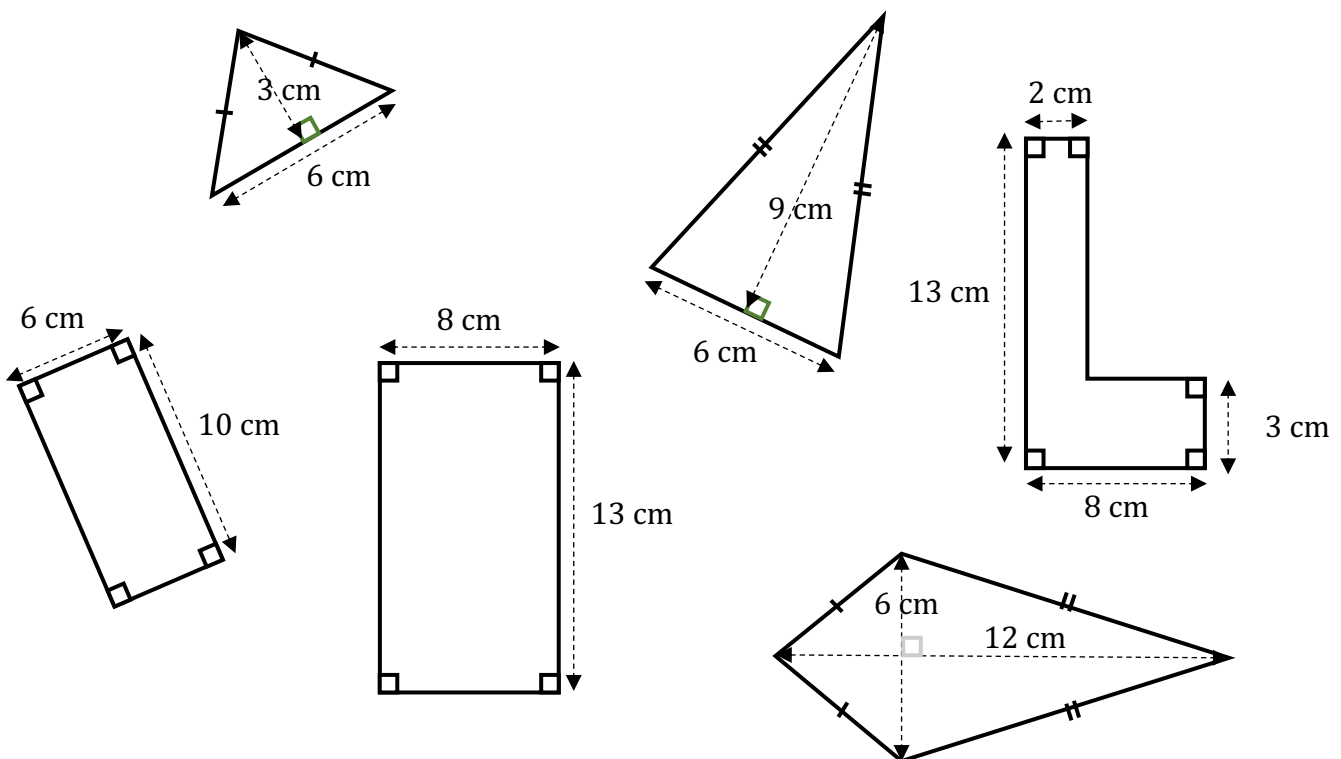

Week 3 Session 1: Indices

Task 1

We can use index notation to describe repeated products.

$$3^1 = 3$$

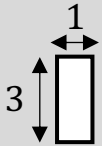
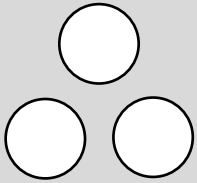

$$3^2 = 3 \times 3$$

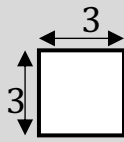
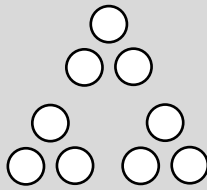

$$3^3 = 3 \times 3 \times 3$$

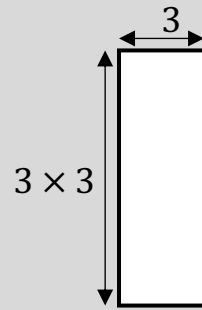
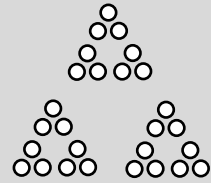

Connect each representation to the calculation.

How could you represent 3^4 ?

Task 2

Is this student correct? Test out her conjecture by trying out other powers.

TIP: You should use at least 8 calculations.

$$3^2 = 3 \times 3 = 9$$

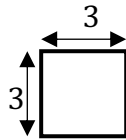

For even powers the result is always a square number

$$2^4 = 2 \times 2 \times 2 \times 2 = 16$$

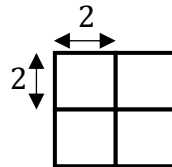

Test out some conjectures of your own.

For example, *odd numbers raised to any power are always odd* OR *the final digit of a power of 2 is always a 2, 4, 6 or 8.*

Week 3 Session 2: Prime factors

Task 1

If you multiply ONLY 1s and 2s, you can make the products 1,2,4,8,16,32 and 64. These have been shaded grey on the grid.

Write down (or circle on the grid) the other numbers that could you make if you are now able to multiply together combinations of 1s, 2s and 3s.

TIP: you do not have to use 1,2 and 3 in each calculation.

E.g. $3 \times 2 = 6$



1	2	3	4	5	6	7	8	9	10
11	12	13	14	15	16	17	18	19	20
21	22	23	24	25	26	27	28	29	30
31	32	33	34	35	36	37	38	39	40
41	42	43	44	45	46	47	48	49	50
51	52	53	54	55	56	57	58	59	60
61	62	63	64	65	66	67	68	69	70
71	72	73	74	75	76	77	78	79	80
81	82	83	84	85	86	87	88	89	90
91	92	93	94	95	96	97	98	99	100

E.g. $3^2 = 9$



Task 2

These students are discussing what happens when you include 4s:

I don't think the list will change!



1	2	3	4	5	6	7	8	9	10
11	12	13	14	15	16	17	18	19	20
21	22	23	24	25	26	27	28	29	30
31	32	33	34	35	36	37	38	39	40
41	42	43	44	45	46	47	48	49	50
51	52	53	54	55	56	57	58	59	60
61	62	63	64	65	66	67	68	69	70
71	72	73	74	75	76	77	78	79	80
81	82	83	84	85	86	87	88	89	90
91	92	93	94	95	96	97	98	99	100

How do you know?



Do you agree? Explain your answer.

Explain what will change when 5s are included.

Task 1

Every compound integer can be written as a **product** of prime numbers.

$$30 = 2 \times 3 \times 5$$

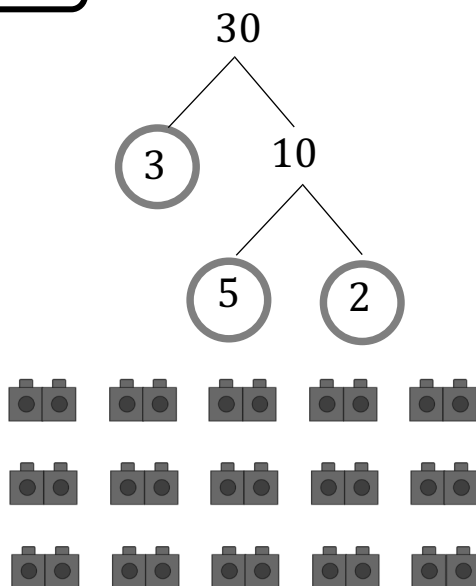
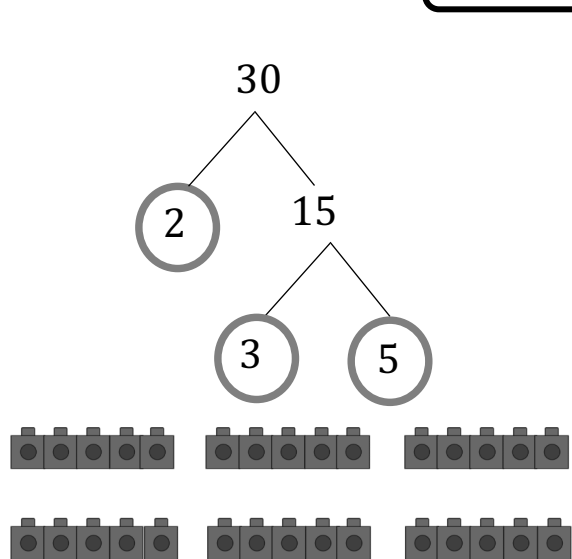

What's the same, what is different about these two representations?

Task 2

Write each of these as a product of prime numbers:

50

150

50×10

50^2

24

72

24×10

24^2

Week 3 Session 4: Using the prime factorisation

Task 1

Here are all the factors of 60.

Write each one as a product of prime factors.

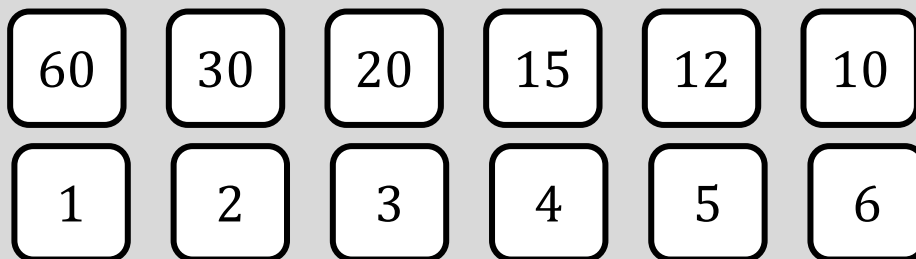

Compare the prime factorisation of 60 with the prime factorisation of its factors.

What do you notice?

Task 2

Help Phil to find **all** the factor pairs for this number:

$$2 \times 5^2 \times 7$$

$$2 \times 5 \times 7$$

$$5$$

$$5 \times 7$$

$$5 \times 2$$

⋮

⋮



Task 1

Two students are looking at the **common factors** of 48 and 32:

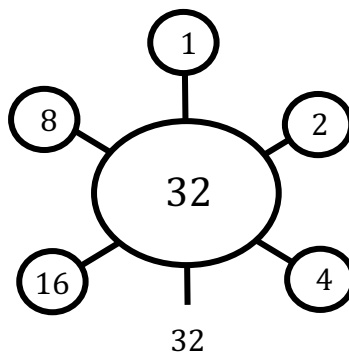
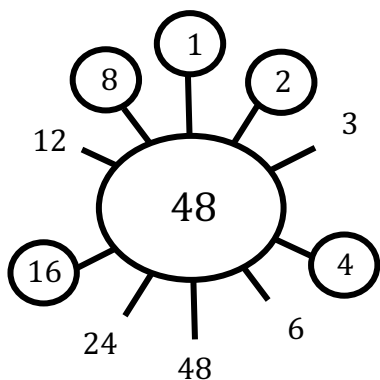

They are the factors of 16!

16 is the highest common factor.



What does Ali mean when he says the *'highest common factor'*?

Task 2

This rectangle has been divided into identical squares.

What is the side length of the squares?

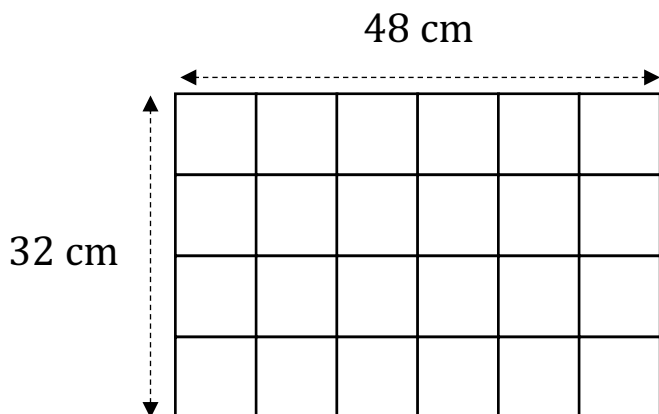

I think these are the largest possible squares.

Do you agree with the student's statement?
What other sized squares can you divide it into?

Explore the different sizes of identical squares that can fit in a 12 cm × 24 cm rectangle. What about an 18 cm × 24 cm rectangle?

Task 1

Venn Diagrams can be used to identify common factors.

$$24 = \underline{2} \times 2 \times 2 \times 3$$

$$36 = \underline{2} \times 2 \times 3 \times 3$$



4 is a common factor!

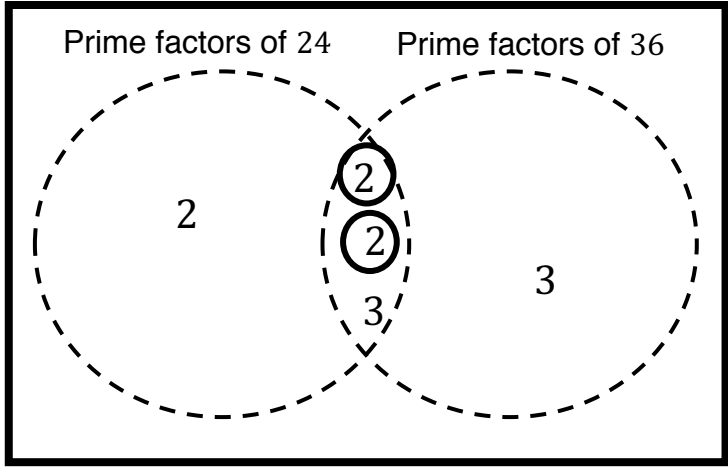

What other common factors can you see?

Task 2

Copy the diagrams below. Explain how each strategy can help find the HCF.

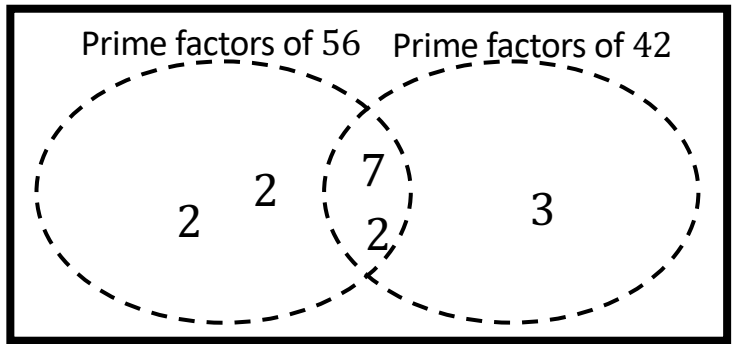
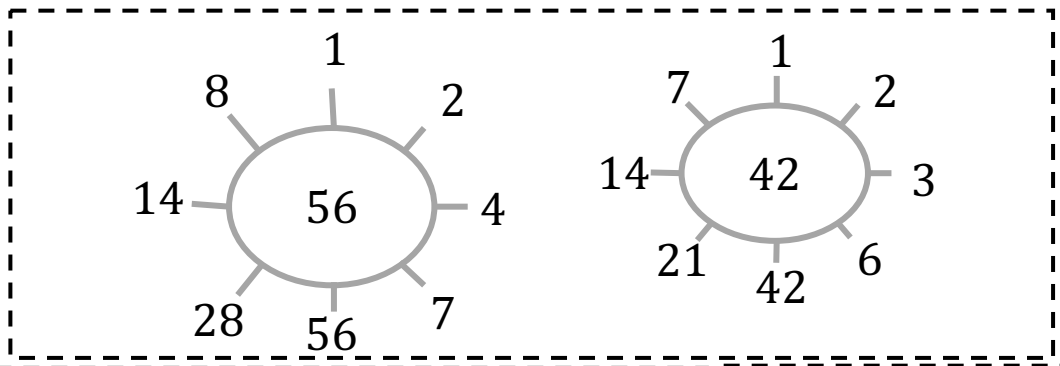

$$56 = 2 \times 2 \times 2 \times 7$$

$$42 = 2 \times 3 \times 7$$

Week 4 Session 3: Lowest common multiple

Task 1

Copy the diagram below. Continue the pattern to help Rosie find the **common multiples** of 45 and 60 up to 180.

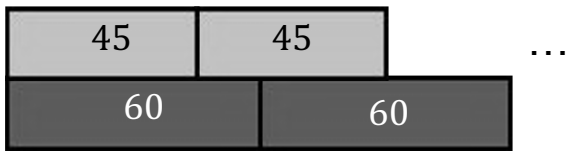

What is the lowest common multiple of 45 and 60 ?

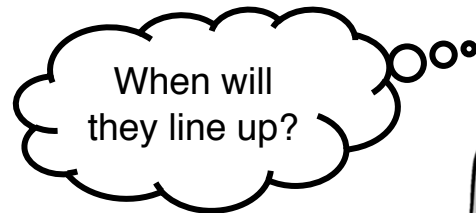

Complete more examples for different pairs of numbers.

Task 2

Select two of the numbers from the list below.

By drawing diagrams and/or listing numbers, find their lowest common multiple:

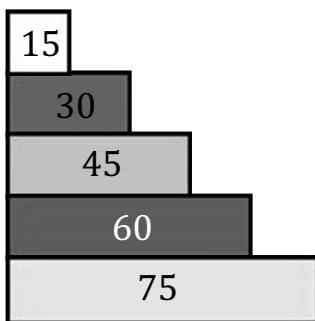

Repeat this for another **three** pairs of numbers.

What do you notice?

Task 1

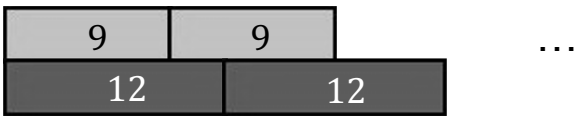

By continuing the pattern above, find the **first five** common multiples of 12 and 9.

Write each as a product of their prime factors.

What similarities are there between each of the product of prime factors?

Task 2

Explain how each strategy can help find the LCM.

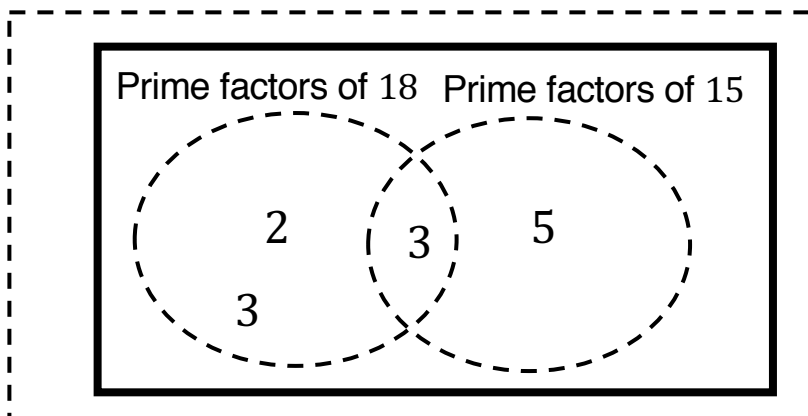
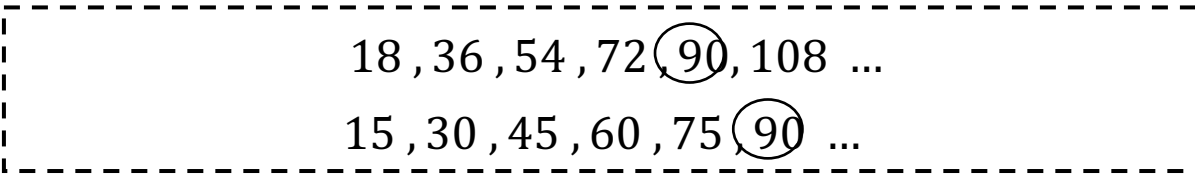
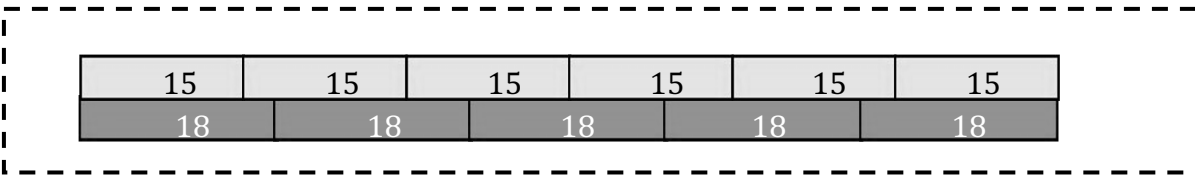

$$90 = \underbrace{2 \times 3 \times 3}_{18} \times \overbrace{3 \times 5}^{15}$$

Task 1

We can use fractions to describe **equal parts** of a whole.

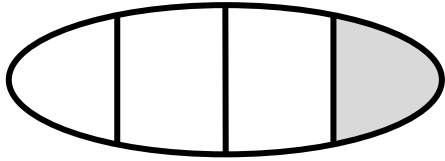

This is not $\frac{1}{4}$

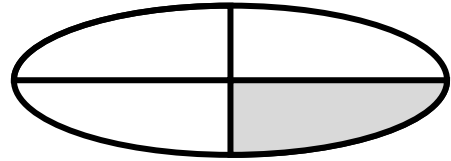

This is $\frac{1}{4}$

Complete the statements below:

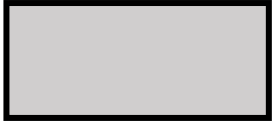

This is 1

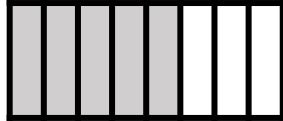

This is $\frac{?}{8}$

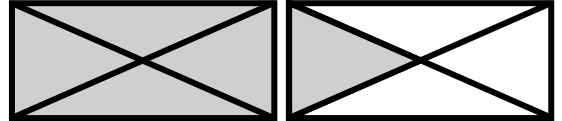

This is $\frac{5}{?} = 1\frac{1}{?}$

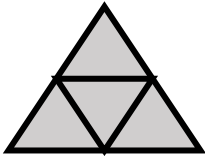

This is 1

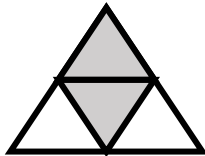

This is...

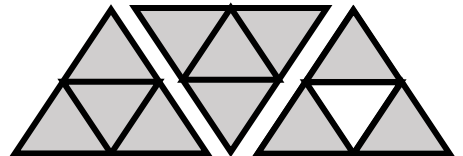

This is...

Task 2

Complete the statements for each set of shapes

Example

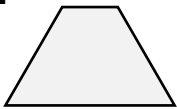
:  = one half
= $\frac{1}{2}$

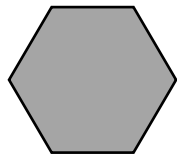
 = one whole = 1 hexagon

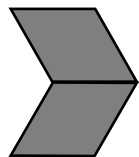
 = two _____
= --

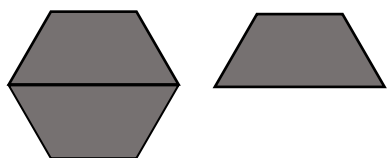
 = _____
=

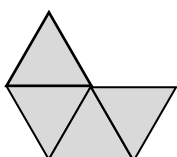
 = _____
=

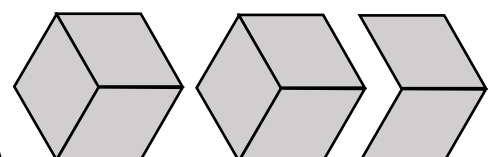
 = _____
=

Task 1

This is a fully-shaded 1 metre bar: 

What fraction of a 1 metre bar is shaded in each diagram?



What fraction of the 1/ of orange juice is shown in each diagram?

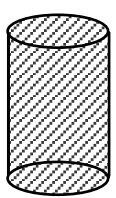

1/

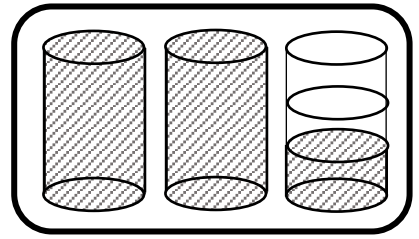
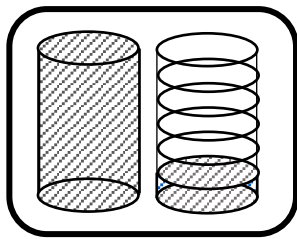
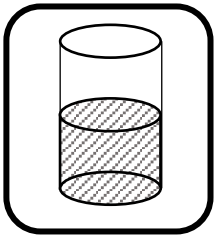

Task 2

This rectangle represents a farm of area 6 acres.



The diagrams below show the farm divided up in two different ways.

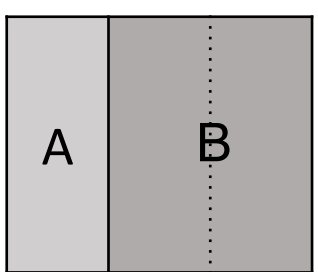

Use the diagrams to complete the statements:

Section A is _____ of the farm or **2** acres

Section B is _____ of the farm or _____ acres

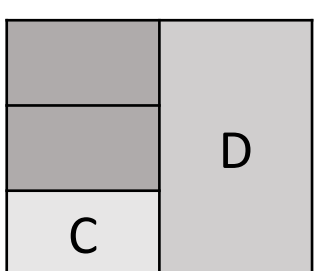

Section C is _____ of the farm or _____ acres

Section D is $\frac{1}{2}$ of the farm or _____ acres

Task 1

Two bars of chocolate are shared **equally** by three children.

They get $\frac{2}{3}$ of a bar each.

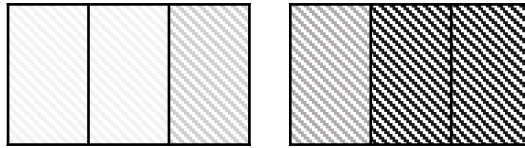

Use some scrap paper to see if you can share two chocolate bars between three children using different cuts.

What would happen to the amount of chocolate each child gets if...

- a) The number of children they are sharing between goes up
- b) The number of chocolate bars they have goes up

Task 2

Look at how chocolate is shared in the two groups below.

Group A

Five bars of chocolate are shared equally by two children.

Group B

Seven bars of chocolate are shared equally by three children.

Who gets more chocolate? Use a diagram to help explain your answer.



Try different numbers of chocolate bars and different numbers of children.

Can you create two **different** groups where each child gets the **same** amount of chocolate?

Task 1

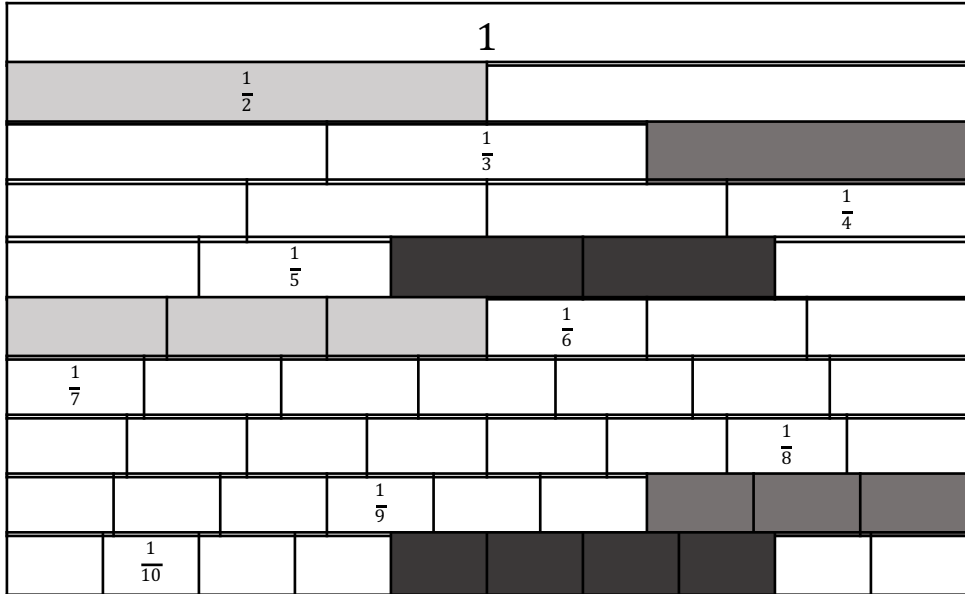
There are many ways to write fractions that represent the same value



 $\frac{1}{2} = \frac{3}{6}$
 $\frac{1}{3} = \frac{\square}{9}$
 $\frac{\square}{\square} = \frac{\square}{\square}$

Find other equivalent fractions from the diagram

Task 2

Fill in the blanks below

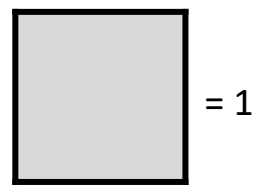

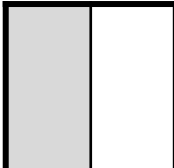
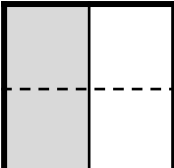
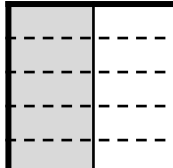
 $\frac{1}{2} =$
 $\frac{2}{\square} =$
 $\frac{\square}{10}$

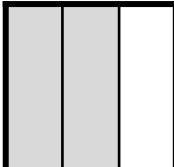
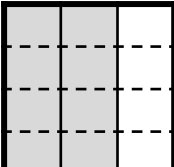
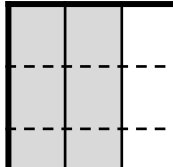
 $\frac{\square}{\square} =$
 $\frac{8}{12} =$
 $\frac{\square}{\square}$

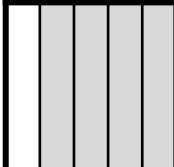
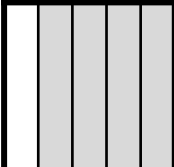
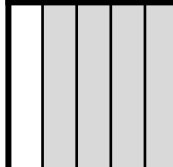
 $\frac{4}{5} =$
 $\frac{8}{\square} =$
 $\frac{\square}{\square}$